

IB Circuits Mock Test

1. An elevator motor can lift a 985 kg elevator 31.5 m in 14.0 seconds.
- What is the power output of the motor? (21.7 kW)
 - If the motor is 91.2% efficient what is the power input? (23.8 kW)
 - If the elevator operates on 240 VAC RMS, what is the current (RMS) it draws, and what is the peak current? (99.3 A, 140. A)
2. The graph shows how the current I varies with potential difference for a resistor R and a light bulb L :

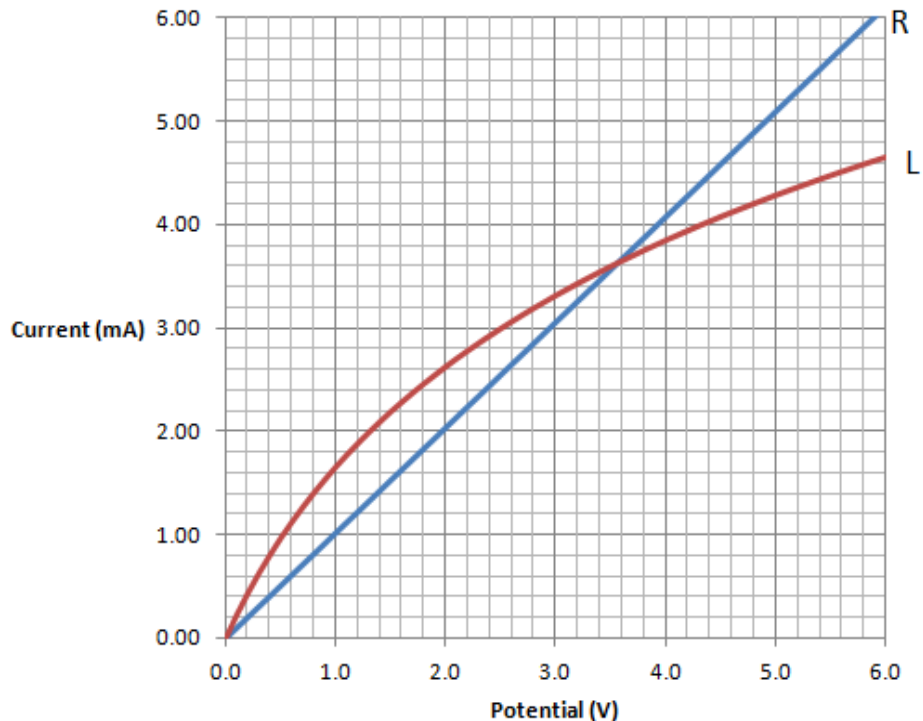

- Explain whether the light bulb or the resistor can be said to be Ohmic.
- What is the resistance of the resistor? (980Ω)
- What is the resistance of the light bulb at a potential of 1 V? (610Ω)
- What is the resistance of the light bulb at a potential of 5 V (1180Ω)
- At what voltage do the resistor and the light bulb have the same resistance? (3.5 V)
- The light bulb and resistor are placed in the circuit diagrammed below. The ideal ammeter reads 8.0 mA. What must be the potential applied by the cell? (4.1 V)

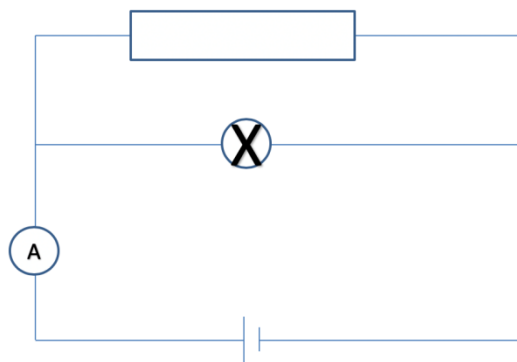

3. Consider the circuit below. Three equivalent light bulbs with a resistance of 7.20 ohms are connected as shown. The cell has a potential of 16.0 V and negligible internal resistance.

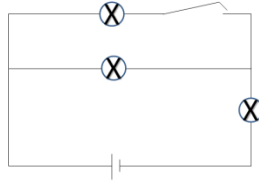

- What is the power supplied by the cell with the switch open? (17.8 W)
- What is the power supplied by the cell with the switch closed? (on) (23.7 W)

4. Consider the circuit below:

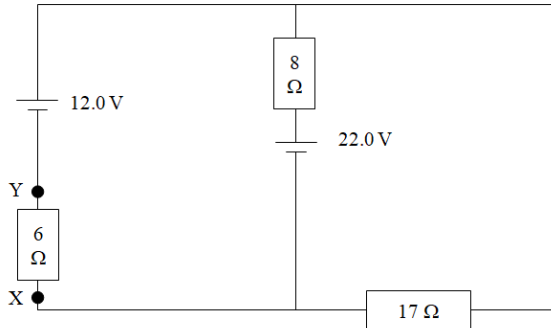

- Calculate the current through the 6, 8, and 17 Ω resistors (0.259 A down, 1.06 A up, 0.797 A left)
- What is the potential difference between X and Y? (1.55 V)
- Explain which is more positive, X or Y (Y is)

5. An ohmic conductor is connected to a power supply. The other parts of the circuit have negligible resistance.

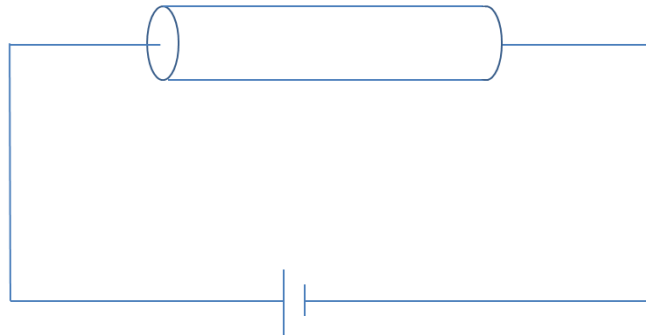

The following data are available for the conductor:

density of free electrons	$n = 7.30 \times 10^{28} \text{ m}^{-3}$
resistivity	$\rho = 3.20 \times 10^{-8} \Omega \text{ m}$
cross sectional area	$A = 4.1 \times 10^{-6} \text{ m}^2$
length	$L = 45.0 \text{ m}$

- If the electron drift velocity v is $4.6 \times 10^{-4} \text{ ms}^{-1}$, what is the current flowing in the conductor? (22.1 A)
- What is the resistance of the conductor? (0.351 Ω)
- What is the potential supplied by the power supply? (7.75 V)
- Show that the potential given by $V = nvqL\rho$